

Important Technical Data

Minimum operating pressure 1.5 bar
Maximum operating pressure 5.5 bar*

Maximum hot water temperature 70°C*
Recommended hot water temperature 46°C

Note: If these temperatures or pressures are exceeded, even for short periods, damage can result. In these instances a thermostatic mixing or pressure reducing valve should be installed.

Abode taps use WRAS, KIWA, NSF or recognised approved components or are manufactured in accordance with recognised European or international standards. Please ensure that your Abode Kitchen mixer is fitted in accordance with Local Water Byelaws.

These installation guidelines have been prepared for your direction and you must exercise due care at all times. We do not accept responsibility for problems that may occur through improper installation. Whilst assembling the tap take care not to accidentally loosen any screwed assemblies.

Abode is a registered trademark of Abode Home Products Limited.

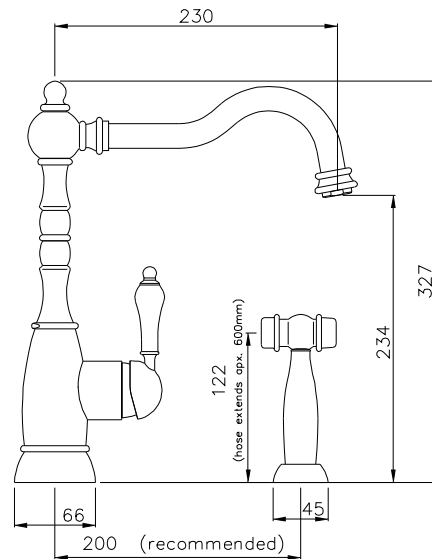

Manufacturers Product Reference

5681-2



Quintessentially...

©Abode
5/2011

abode

Abode Home Products Limited, Unit L,
Zenith Park, Whaley Road, Barnsley,
S75 1HT.
Tel: 01226 283434 Fax: 01226 282434
www.abode.eu

All errors and omissions excepted.

Bayenne Single Lever with integrated spray



5 Year Warranty, Terms And Conditions

In the unlikely event that you should experience any defect in the materials or workmanship of your new Abode mixer within FIVE years of purchase, the purchaser's sole remedy shall be the replacement (at the manufacturer's discretion) of all or any part of the product that is defective. All working parts and valves are guaranteed for a period of FIVE years from purchase. Decorative surface finishes and O-rings are guaranteed for FIVE years from the date of purchase provided that our advice concerning care has been observed and no scouring agents have been used.

This is provided that the mixer has been used for normal domestic purposes in the UK and that the care, installation and maintenance instructions have been observed. The warranty extends to the original purchaser only. You should retain a copy of your dated invoice as proof of purchase to validate any claims under this guarantee.

Marks, scuffs and scratches caused by improper installation or accidental damage are not covered by this guarantee.

Neither are shade variations or any damage or defect caused by incorrect installation or abuse of the fitting.

As we are continuously improving and developing our range of products, finishes & colours, in the event of a valid claim, we may not be able to provide an identical replacement for the defective product throughout the guarantee period. Where an identical product is no longer available, we will supply the nearest equivalent from our then current product range. In assessing your claim, we must be given the opportunity to inspect the product as installed prior to removal. Any product returns must be packaged as received and complete.

No other warranties, express or implied, are made, including merchantability or fitness for a particular purpose. Under no circumstances shall the manufacturer be liable for any loss or damage arising from the purchase, use or inability to use this product, or for any special, indirect, incidental or consequential damages. No liability is accepted for consequential damage to other household fixtures, fittings or furnishings arising from this claim, even if attached to the product. No installer, dealer, agent or employee of Abode Home Products Limited has the authority to modify the obligations or limitations of this warranty.

Q

Please leave these instructions for your customer.

Parts and Contents:

Key	Description	Qty
A	Mixertap body	1
B	Threaded fixing column	1
C	Upper seal	1
D	Triangular stabilising bracket	1
E	Lower rubber washer	1
F	Metal washer	1
G	Fixing nut	1
H	Flexible tail pipes	2
I	Spray outlet hose	1
J	Fibre washer	1
K	Nylon pull out hose	1
L	Fixing nut	1
M	Metal washer	1
N	Rubber washers	2
O	Sprayhead body	1
P	Pull out hose nut	1
Q	Rubber washer	1
R	Non return valve (internal to sprayhead)	1
S	Sprayhead	1

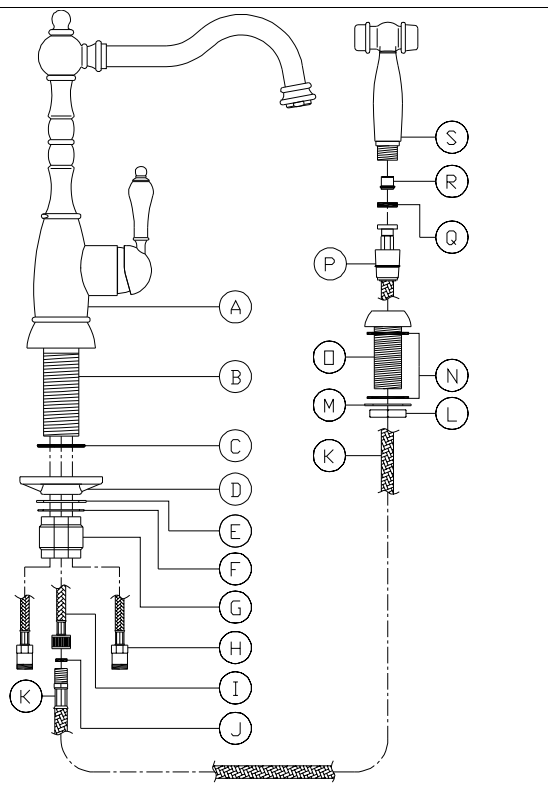

Installation Preparation:

All parts should be removed from their packaging and inspected for any transport damage prior to installation. You should check you have the required hot and cold supply pressure also.

Before installing the new mixer it is essential that you thoroughly flush through the supply pipes in order to remove any remaining solder, swarf or impurities from your system. Failure to carry out this simple procedure could cause problems or damage to the workings of the mixertap.

We recommend installing particle filters and isolation valves to both the hot and cold feed pipes in an accessible position. This will help to prevent premature failure of the valves and ease any future maintenance.

Shut off your water heating system and ensure that your mains stopcock is closed. Open the lowest hot and cold taps in the house and allow the water to run until the cold-water storage tank and pipes are fully empty. Please note, the hot water storage cylinder (if applicable) may remain full.

This mixertap requires 2 x 35mmØ tap holes, if replacing an existing tap, remove the tap & clean the end of the feed pipes using wire wool the tap hole area should be free from dirt and sealant. Loosely position the tap and tail pipes to check if any alteration to the existing pipework is required, if this is the case do this now.

If placing the tap or spray through a worktop for example the taphole should be sealed in accordance with the worktop manufactures instructions, your should pay particular care that the seal between the worktop and the tap is correctly seated.

Installation:

1. Pass the upper seal (C) over the threaded fixing column(B). Pass the threaded fixing column through the tap hole.
2. Whilst holding the tap in place on the tap hole, pass the lower rubber washer (E), metal washer (F) then fixing nut (G) over the flexible tail pipes (H) onto the threaded fixing column(B).

Nb. you may need to pass the flexible tail pipes through the above parts one at a time by gently bending the pipes. The Triangular stabilising bracket (D) is only required when fitting the tap to a stainless steel sink.

3. Whilst holding the tap centrally to the tap hole and the logo on the base plinth facing forward tighten the fixing nut (G).
4. Connect the hot and cold tail flexible pipes (H) to the water mains using ½" BSPx15mm compression fittings. Note: Non-return valves are factory fitted into tail pipes (H).
5. Push the (upper) rubber seal (N) onto the sprayhead body (O), then pass the sprayhead body (O) through the 2nd taphole. Now pass the (lower) rubber washer (N), then metal washer (M) over the sprayhead body (O).
6. With the sprayhead body (O) central to the 2nd taphole tighten fixing nut (L) onto sprayhead body (O) to fix its position.
7. Screw the hose nut (P) onto the sprayhead (S) ensuring that rubber seal (Q) is present in the joint.
8. Pass the pull out hose (K) through the top of the sprayhead body (O), screw the pull out hose (K) into the spray outlet hose (I) ensuring that fibre seal (J) is present in the joint.

After Installation:

Once you have visually checked the installation of the new tap and all connections, ensure that all other fittings are closed except the new tap which should be left open. Turn on your water heating system and ensure that your mains stopcock is open. Reconnect both the hot and cold water supplies to this fitting. Check the function of flow and function of hot, cold and mixed water.

Turn off the tap and check carefully for any leaks around all connections on the fitting and adjoining plumbing. If possible return to the installation after a longer period to double check for slower leaks. If pressure testing equipment is available check the installation to the maximum recommended pressure.

Clean the tap to remove any marks created during installation as instructed then place a bag over the product to protect the tap until it is ready for use. The installation should be periodically checked for damage, if the property is left unattended for a prolonged period we recommend isolating water supplies.

Care Instructions For Your Kitchen Sink Tap:

To maintain the appearance of this product, **ensure that it is regularly cleaned only using a clean, soft damp cloth.** A solution of warm water and a mild liquid detergent may be used where necessary, and then the fitting rinsed thoroughly and wiped dry. **Any other cleaning action will invalidate your warranty.** If the mixertap has a diffuser it should be unscrewed and cleaned periodically in water.

Abrasive cleaners, scouring cleaners and acidic cleaners must not be used under any circumstances. Avoid contact with all solvents (including chlorinated solvents, ketones or acetones as these may result in surface deterioration or etching). Also avoid contact with any harsh household chemicals such as oven cleaners, drain cleaners, rust removers, paint strippers and toilet bowl cleaners, bar keepers friend or Brasso.

