



Product features:

- Metal & ABS construction
- Thermostatic valve for safety & comfort
- Custom designed for lower range pressures
- Can be installed concealed or exposed
- Luscious European quality chromium plate finish

Packaged properties:

Box length: 270 mm **Box depth:** 155 mm
Box width: 235 mm **Boxed weight:** 3.14 kg

Includes pop up waste?: No

Additional comments:

Includes parts to install conceal or exposed

Product dimensions:

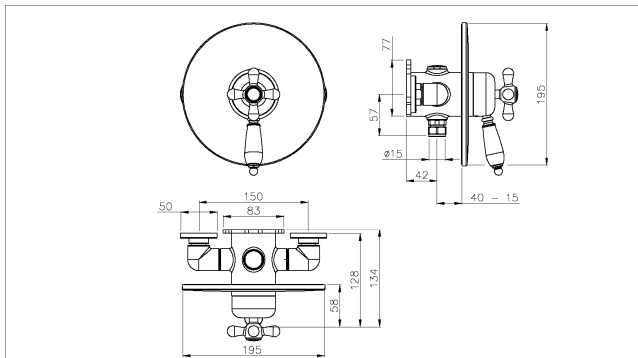

Euphoria
 traditional combined exposed / concealed
 thermostatic shower mixer
 (shown in concealed format)

AB2003 v1

(c) abode home products ltd
 www.abode.eu

abode

our policy is to continually
 improve and develop products,
 and accordingly we reserve the
 right to amend specifications
 without prior notice

- **Overall Height / projection:** 128 or 58 mm
- **Exit reach:**
- **Exit height:**
- **Centre distance(s):** 150 mm

- **Base diameter(s):** 195 or 50 mm
- **Product mounted where:** Wall
- **Recommended hole diameter:**
- **Min. fitting depth required:** 82 mm
- **Max. surface depth:**

Product flow characteristics:

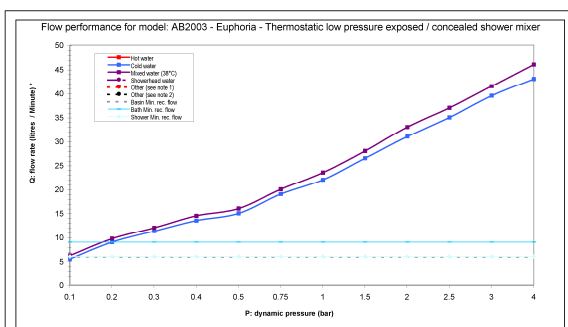

note 1: hot water temperature = maximum achievable by selection

note 2: hot water temperature = maximum achievable by selection

© abode, not to be reproduced without prior permission

*flow rate data shown is correct at the time of testing, abode reserves the right to amend specifications without prior notice. Min. flow rates according to BS68

- **Min / Max water pressure:** 0.20 / 5 bar
- **Part G mixed flow rate at 3 bar (l/m):** 41.5

- **Max water temperature:** 70° C
- **Product flow characteristics:**
- **Aerator type:**
- **Includes output diverter?:** No
- **Control valve type:** Thermostatic ()
- **Non return valve position:** h&c inlet
- **Mesh particle filter size:** 0.50 mm
- **Inlet / outlet size:** 1/2" M /
- **Inlet type / length:** Rotating fixed / mm
- **Shower hose type / length:**

Warranty Summary (Full details available on request):

- Materials and workmanship defects warranted for 5 years
- Valves and working parts warranted for 2 years
- Surface warranty defects warranted for 1 year
- O-rings, hoses & gaskets warranted for 1 year

Care instructions:

- Clean the mixers and showers regularly as required, using soap, do not use any other cleaners.
- Regular cleaning will prevent the build up of lime scale and dirt
- After cleaning rinse thoroughly with clean water to remove any cleaner residue
- Residues of liquid soaps, shampoos and shower foams can also cause damage, so rinse with clean water after using, avoid contact with any abrasives