

**BHC635SS**  
**60cm touch control**  
**ceramic hob**

**INSTRUCTION MANUAL**

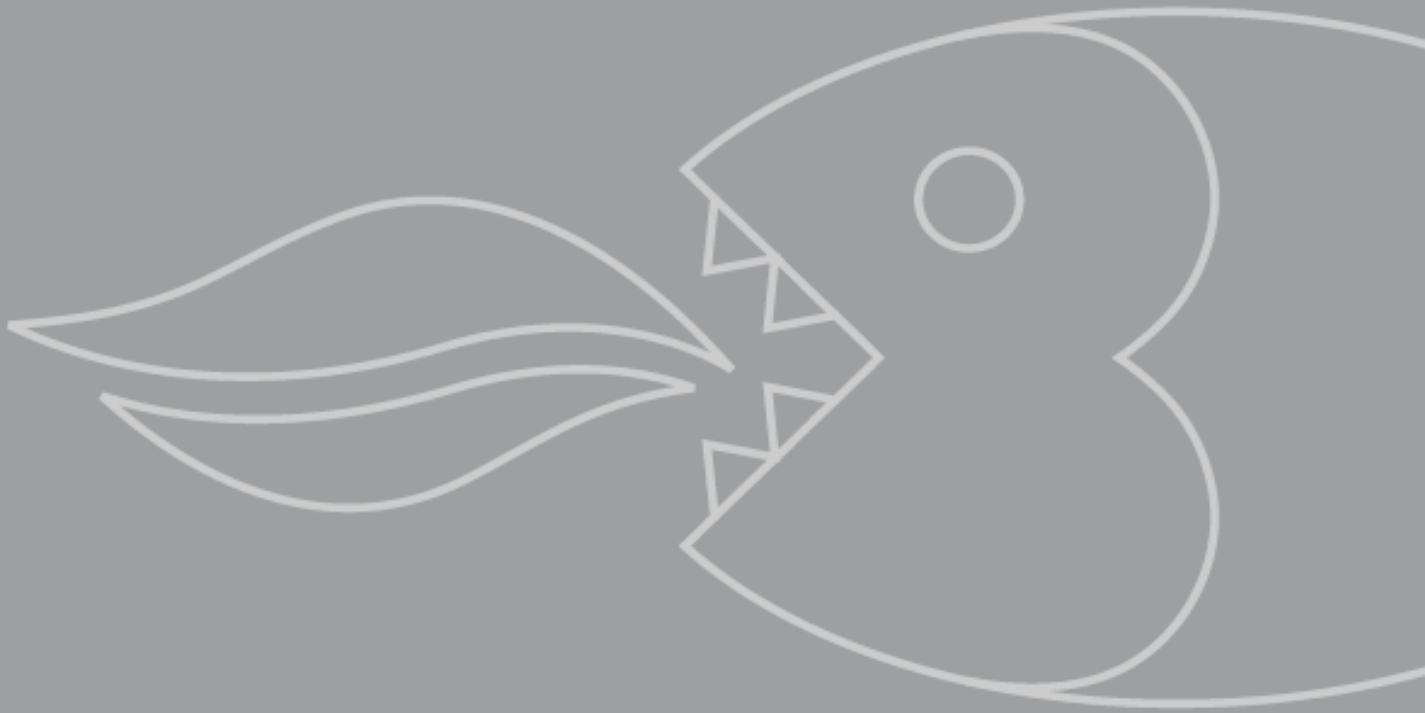

# User Manual for your Baumatic

## BHC635SS

60 cm Front touch control  
4 zone ceramic hob



***NOTE: This User Instruction Manual contains important information, including safety & installation points, which will enable you to get the most out of your appliance. Please keep it in a safe place so that it is easily available for future reference; for you or any person not familiar with the operation of the appliance.***

# Contents

<b>Environmental note</b>	4
<b>Important safety information</b>	5 – 8
<b>Specifications</b>	8 – 10
Ceramic hob layout	9
Control panel layout	10
<b>Using the ceramic hob</b>	10 - 18
Before first use	10
Touch controls	11
Switching the hob top on	11
Switching on a zone and setting a power level	11
Switching off a zone	12
Switching off the hob	12
Residual heat indicator	13
Switching on the dual cooking zone	13 - 14
Locking the hob top	14
The hob timer	15
Setting a countdown time	16
Safety cut-off	17
Automatic switch off function	17
Automatic heating function	17 - 18
<b>Hob guidelines</b>	18 – 19
Cooking guide	18
<b>Cleaning and maintenance</b>	20 - 21
Cleaning the ceramic hob top	20
After each use	20
Cleaning table	20
Using a ceramic hob scraper	21
Using a specialist ceramic hob cleaner	21
<b>Installation</b>	21 - 27
Positioning	22
Unpacking the appliance	22
Installing the appliance	23 – 25
Electrical connection	25 - 26
Connecting the mains supply cable	26
Replacing the mains supply cable	27
<b>My appliance isn't working correctly</b>	27 - 29
<b>Contact details</b>	30

**This appliance is marked according to the European directive 2002/96/EC on Waste electrical and Electronic Equipment (WEEE). By ensuring this product is disposed of correctly, you will help prevent potential negative consequences for the environment and human health, which could otherwise be caused by inappropriate waste handling of this product.**

The symbol  on the product, or on the documents accompanying the product, indicates that this appliance may not be treated as household waste. Instead it shall be handed over to the applicable collection point for the recycling of electrical and electronic equipment.

**Disposal must be carried out in accordance with local environmental regulations for waste disposal.**

**For more detailed information about treatment, recovery and recycling of this product, please contact your local city office, your household waste disposal service or the shop where you purchased the product.**



- The packaging materials that Baumatic uses are environmentally friendly and can be recycled.
- Please discard all packaging material with due regard for the environment.

## Important safety information



Your safety is of the utmost importance to Baumatic. Please make sure that you read this instruction booklet **before** attempting to install or use the appliance. If you are unsure of any of the information contained in this booklet, please contact the Baumatic Advice Line.

### General Information

- This appliance is designed for domestic household use and for the cooking and frying of domestic foodstuffs.
- **IMPORTANT:** *The adjacent furniture and all materials used in the installation **must** be able to withstand a minimum temperature of 85°C above the ambient temperature of the room it is located in, whilst in use.*
- Certain types of vinyl or laminate kitchen furniture are particularly prone to heat damage or discolouration at temperatures below the guidelines given above.
- Any damage caused by the appliance being installed in contravention of this temperature limit, **will be the liability of the owner.**
- Your new appliance is guaranteed against electrical or mechanical defects, subject to certain exclusions that are noted in Baumatic's Conditions Of Guarantee. The foregoing does not affect your statutory rights.
- The use of this appliance for any other purpose or in any other environment without the express agreement of Baumatic Ltd. will invalidate any warranty or liability claim.
- You should not use this appliance to store items on or as a work surface.
- No modifications to the appliance are permitted by Baumatic Ltd.
- You should not store or place flammable or highly flammable liquids/materials on top of or near the appliance. Items made from aluminium, plastic or plastic film should also be kept away from the appliance, as they may fuse to the surface.
- **Repairs may only be carried out by Baumatic service engineers or their authorised service agent.**

## Child Safety

- Baumatic strongly recommend that babies and young children are prevented from being near to the appliance and not allowed to touch the appliance **at any time**. During and after use, all surfaces will become hot.
- If it is necessary for younger family members to be in the kitchen, please ensure that they are kept under close supervision at all times.
- Older children should only be allowed to utilise the appliance when supervised.

## General Safety

- ✓ The appliance should only be installed and connected by a suitably qualified person.
- ✓ Care should be taken to ensure that the units and work surfaces that you build the appliance into, meet with the relevant standards.
- ✓ If you notice any scratches, splits or cracks in the ceramic glass, you should immediately switch off the appliance and disconnect it from your mains supply. Otherwise there is the risk of electric shock occurring.

## During use

- ✓ Any film or stickers that are present on the hob surface when it is delivered should be removed before use.
- ✓ Care should be used when utilising the appliance, otherwise there is a risk of burns being caused.
- You should not allow the electrical connection cables to come into contact with the hob surface when it is hot or any hot cookware.
- If fat and oil overheats, then it can ignite extremely quickly. For this reason, when cooking with fat and oil the appliance should not be left unattended.
- ✓ Make sure that all of the cooking zones are switched off after use.

## Cleaning

- Cleaning of the hob should be carried out on a regular basis.
- **IMPORTANT:** *Before attempting to clean the appliance, it should be disconnected from the mains and allowed to cool.*
- Great care should be taken whilst using this appliance and when following the cleaning procedure.
- You should not use a steam jet or any other high pressure cleaning equipment to clean the appliance.

## Installation



***This appliance must be correctly installed by a suitably qualified person, strictly in accordance with the manufacturer's instructions. Please see the specific section of this booklet that refers to installation.***

- ***Baumatic Ltd. declines any responsibility for injury or damage, to person or property, as a result of improper use or installation of this appliance.***

## Declaration of conformity

This appliance complies with the following European Directives:

- 2006/95/CE General regulations / Low tension
- 1935/2004/CE 90/128/EEC This appliance is suitable to come in contact with food
- 2004/108/CE Electromagnetic compatibility
- The manufacturer declares that the hob is built using certified materials and requires the appliance to be installed in accordance with the standards currently in force. This appliance must be used by a trained person for domestic purposes only.

## To avoid damaging your appliance

- The ceramic glass can be damaged by objects falling onto it.
- The ceramic glass edge can be damaged by knocks from cookware.
- Cast iron and cast aluminium cookware with damaged bases may scratch the ceramic surface if they are dragged across it.

- Pans should be lifted on and off the hob surface and not dragged.
- Cooking zones should not be switched on without cookware placed on it. Also the cookware should not be empty.

## Specifications

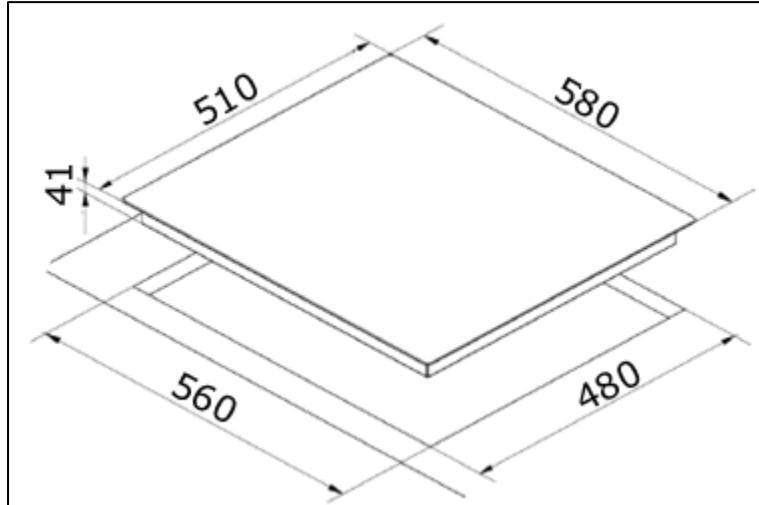

### Product dimensions:

Depth: 510 mm  
 Width: 580 mm  
 Height: 41 mm

### Aperture dimensions:

Depth: 480 mm  
 Width: 560 mm

### Product specifications:

- 1 x 1.80 kW hyperspeed zone (Ø 180 mm)
- 2 x 1.20 kW hyperspeed zones (Ø 140 mm)
- 1 x 0.75 - 2.20 kW double hyperspeed zone (Ø 120/210 mm)
- Front touch control operation
- 4 individual residual heat indicators
- Safety lock
- Timer
- Automatic heating function
- Stainless steel frame

### Standard accessories

- Ceramic hob scraper



## Electrical details

<b>Rated Voltage:</b>	220 - 240 Vac 50 – 60 Hz
<b>Supply Connection:</b>	35 A (double pole switched fused outlet with 3mm contact gap)
<b>Max Rated Inputs:</b>	6.4 kW
<b>Mains Supply Lead:</b>	3 core x 6 mm <sup>2</sup> (not supplied)

For future reference please record the following information which can be found on the rating plate and the date of purchase which can be found on your sales invoice. The rating plate of your hob is located on the underneath of the appliance. Therefore it is a good idea to record this information before you install your appliance.

**Model Number** .....

**Serial Number** .....

**Date of Purchase** .....

## Ceramic hob surface layout

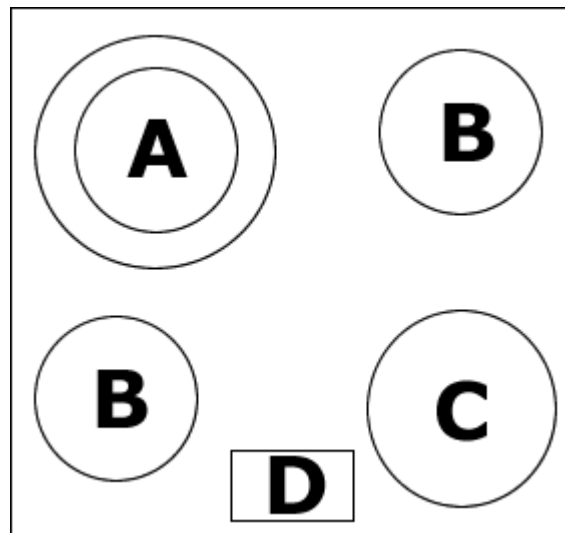

**A** = 0.75 – 2.20 kW dual plate (Ø 120 – 210 mm)

**B** = 1.20 kW hi-light plate (Ø 140 mm)

**C** = 1.80 kW hi-light plate (Ø 180 mm)

**D** = Control panel

## Control panel layout

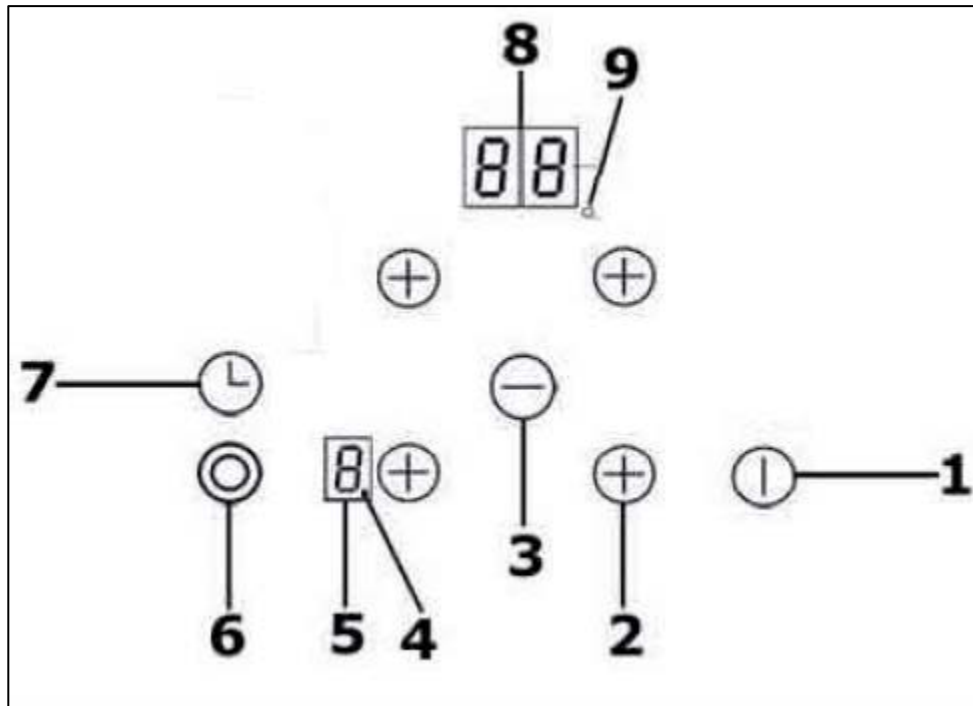

- 1) ON / OFF button
- 2) Plus / selection button
- 3) Minus button
- 4) Decimal point symbol
- 5) Cooking zone indicator
- 6) Dual circuit ON / OFF button
- 7) Timer button
- 8) Timer display
- 9) Timer cooking zone indicator

## Using the ceramic hob

### Before first use



**IMPORTANT:** You should clean the ceramic hob surface (see "Cleaning and maintenance" section).

- You should switch on one cooking zone at a time, for 5 minutes at the maximum setting. This will help to eliminate any new smell that exists and evaporate any humidity that has formed on the heating elements during transit.
- Do not burn off more than one zone at once.
- **You must** place a saucepan filled half full with cold water on each zone as you burn it off.

## Touch controls

- All operations are performed by means of the touch controls that can be found on the control panel.
- Each touch control has a visual display that corresponds to it.

## Switching the hob top on

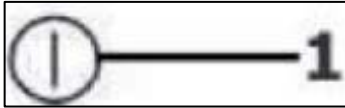

- Press the ON/OFF button **(1)** to switch on the appliance.

- All of the cooking zone indicators will light briefly then go out.
- This means that the hob has entered stand-by mode.

## Switching on a zone and setting a power level

**IMPORTANT:** A zone must be selected within 2 minutes of switching the hob on.

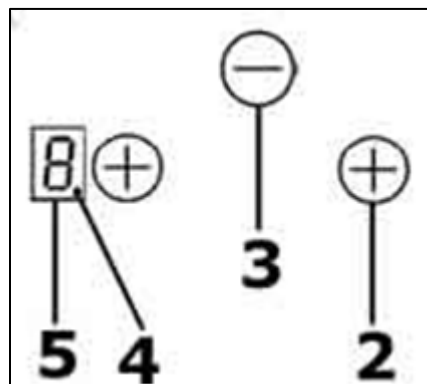

- Press the cooking zone plus button **(2)** of the zone that you want to use.
- Adjust the zone between power levels 1 and 9, using the plus **(2)** and minus **(3)** buttons. By holding down either of these buttons, the value on the zone indicator **(5)** will adjust up or down.

## Switching off a zone

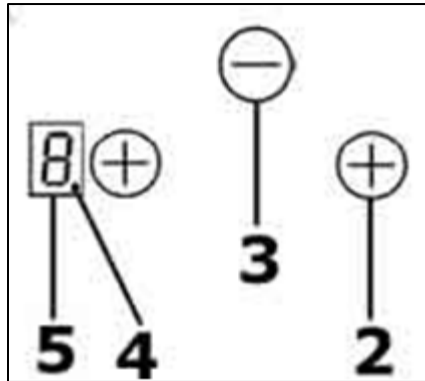

- Press the cooking zone selection button **(2)** of the zone that you want to switch off.
- Hold the minus button **(3)** down until the number in the cooking zone indicator reaches "0". After a few seconds, the zone will switch off automatically.
- Alternatively you can press the plus **(2)** and minus **(3)** buttons simultaneously to set the power level back to "0".
- The letter "H" will show in the cooking zone indicator **(5)**, (see the section on the "residual heat indicator"), if the appliance is still hot.

## Switching off the hob

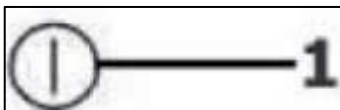

- Once you have switched off all of the cooking zones, you should turn off the hob.
- Press the ON/OFF button **(1)**.
- It is possible to turn the hob off at any time by pressing the ON/OFF button **(1)**.

## Residual heat indicator

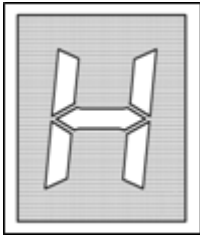

- After a zone is switched off, the corresponding cooking zone indicator **(5)** will show a flashing letter "H". This means that the temperature of the zone is over 60°C and is therefore still high enough to cause injury.
- When the temperature of the zone falls below 60°C, then the letter "H" will go out.
- **IMPORTANT:** *The residual heat indicator will disappear if the mains supply to the product is cut.*
- **IT IS STILL POSSIBLE TO BURN YOURSELF ON A HOB ZONE, EVEN WHEN THE TEMPERATURE OF IT HAS DROPPED BELOW 60°C.**

## Switching on the dual cooking zone

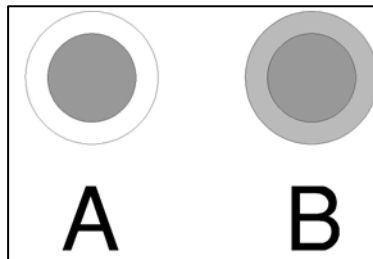

The dual cooking zone has two cooking areas that you can use; a central section and an outer section. You can use the central section **(A)** independently or both sections **(B)** at once.

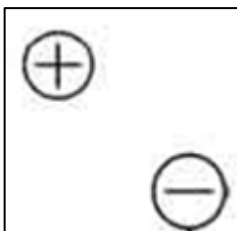

- Press the cooking zone plus button **(2)** for the dual circuit zone.
- Adjust the zone between power levels 1 and 9, using the plus **(2)** and minus **(3)** buttons. By holding down either of these buttons, the value on the zone indicator **(5)** will adjust up or down.
- The central section of the dual cooking zone will switch on.



- If you wish to activate the outer section as well, you should press the dual cooking zone ON/OFF button **(6)**. A neon above the button will light.

- To switch the outer section off, you should press the dual cooking zone ON/Off button again. The neon above the button will go out and the outer section will go off.
- To switch off the zone after use, press the cooking zone selection button **(2)** of the dual cooking zone.
- Hold the minus button **(3)** down until the number in the cooking zone indicator reaches "0". After a few seconds, the zone will switch off automatically.
- The letter "H" will show in the cooking zone indicator **(3)**.

### Locking the hob top

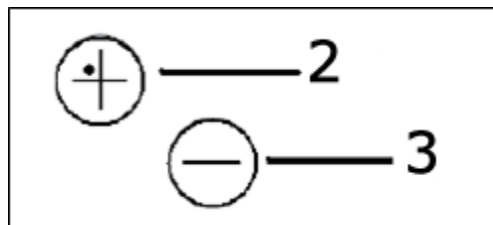

- The whole hob top can be locked by pressing the plus **(2)** and minus **(3)** buttons simultaneously and then pressing the minus button **(3)** again.
- All displays will show "L" to indicate that the safety lock feature has been activated.
- This sequence must be carried out within 10 seconds and no other buttons other than the ones stated should be pressed. When the safety lock has been switched on, it will disable any of the other buttons on the control panel, apart from the ON/OFF button **(1)**.
- The hob top will remain in the locked state until the lock is released. Even if the hob is switched off, the hob top will still be locked when it is turned on again.

- To disable the safety lock feature, you should press the plus **(2)** and the minus **(3)** buttons simultaneously. The "L" symbol will disappear from the display and all cooking zones will show "0" with a flashing dot.

### The hob timer

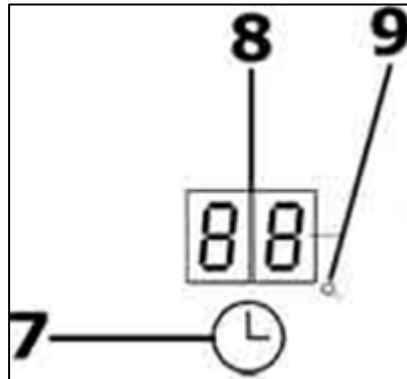

*Your hob has a timer which will countdown a period of time between 1 and 99 minutes. At the end of the countdown period an audible signal will sound.*

- When the touch control is switched off the timer function can be activated using the timer button **(7)**. Use the plus **(2)** and minus buttons **(3)** to set the countdown time.
- The timer display will show the countdown time that is being set.
- If the set time exceeds 99 minutes, the timer display will return to showing 0.
- Once the timer has been set, the countdown will start and an audible signal will sound when the set time is reached. You can adjust the countdown time by pressing the plus or minus buttons.
- The sound signal will stop when any button is pressed. The display will stop flashing and go off after a few minutes.
- *If the touch control is turned on using the power supply button **(1)** the timer will go off automatically.*

## Setting a countdown time

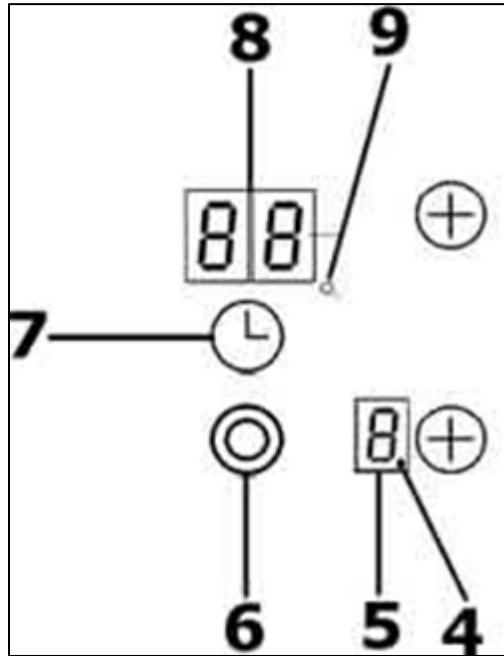

- Press the ON/OFF button **(1)** to switch on the appliance.
- Press the cooking zone plus button **(2)** of the zone that you want to use.
- Adjust the zone between power levels 1 and 9, using the plus **(2)** and minus **(3)** buttons. By holding down either of these buttons, the value on the zone indicator **(5)** will adjust up or down.
- Press the timer button **(7)** and the timer display **(8)** will flash.
- Set the countdown time that you require, using the plus **(2)** and minus **(3)** buttons.
- When the countdown time that you require appears on the timer, stop pressing the timer buttons.
- The timer display **(8)** will flash for 5 seconds, when it stops flashing; the countdown time will be set. Alternatively you can press the timer button **(7)** again to confirm the countdown time.
- The completion of the countdown time will be indicated by an audible sound and the hob will switch off completely.



**IMPORTANT:** The countdown timer can be used for individual cooking zones. When this function is used, the hob will switch off by entering stand-by mode.



## Safety cut-off

- When the control panel detects an ambient temperature greater than 95°C it will shut off all the cooking zones.
- A cooking zone that has been shut off by the thermal protection can only be used again when the temperature drops below 95°C.



**IMPORTANT:** *The hob will still be dangerously hot even after it is usable again.*

## Automatic switch-off function

- Based on the power level, each cooking zone is shut off after a maximum preset time if no buttons are pressed. Each time an action is performed, such as pressing a button, the maximum operation time is reset.
- The appliance can be switched off at any time by pressing the power supply button **(1)** even if the safety lock is in use.

## Automatic heating function

When the automatic heating function is activated, the power of the cooking zone reaches 100% for an established heating time depending on the power level set. This allows the cooking zone to heat to the full capacity of the required power level in a much quicker time.

- To activate this function, set the power level of the chosen zone to 9 and then press the plus button **(2)** again.
- Use the plus **(2)** and minus **(3)** buttons to select the desired power level.
- Approximately 3 seconds after the power level is set, an "A" symbol will appear on the cooking zone display alternating with the chosen power level.
- If you press the minus button **(3)** during this time, the automatic heating function will be cancelled.
- If you press the plus button **(2)** during this time, you can select a higher cooking level and the duration for automatic heating will change accordingly.

- When the automatic heating function is complete, the display will show the selected power level and the cooking zone will be working to the full capacity of that power level.
- For a general guide to the duration of automatic heating for the different power levels please see the table below:

<b><i>Power level</i></b>	<b><i>Automatic heating time (seconds)</i></b>
1	60
2	180
3	288
4	390
5	510
6	210
7	210
8	270
9	10

### **Cooking guide**

- For cooking suggestions for the different power levels please see the table below:

<b><i>Touch control Power level</i></b>	<b><i>Cooking suggestions</i></b>
0	Off.
1 – 2	For melting processes (butter or chocolate).
2 – 3	For keeping foods hot and heating small amounts of liquids.
3 – 4	For heating larger amounts and beating custards and sauces.
5	Slow boiling for soups, pasta and risotto.
6	Continuing steaming processes, cooking steaks and fried foods in general.
7	Browning meats, roasted potatoes, fried fish etc.
8	Bringing large amounts of water to the boil.
9	Quick-frying, char-grilled steaks etc.

### **Hob guidelines**

- The first few times the hob top is used, it may give off an acrid, burning smell. This smell will disappear completely with repeated use.
- The worktop is fitted with cooking areas of different diameter and power.

- The positions where the heat will radiate from are clearly marked on the hob top. The saucepans must be positioned exactly on these zones for efficient heating to occur. Pans should have the same diameter as the cooking zone that they are being used on.
- You should not use saucepans with rough bottoms, as this can scratch the ceramic surface.
- Before use, make sure that the bottoms of the saucepans are clean and dry.
- When cold, the bottom of the pans should be slightly concave, as they expand when hot and lie flat on the surface of the hob. This will allow the heat to transfer more easily.
- The best thickness for the bottom of the pans is 2 – 3 mm for enamelled steel and 4 – 6 mm for stainless steel with sandwich type bottoms.
- If these rules are not followed, then there will be a great loss of heat and energy. Heat not absorbed by the saucepan, will spread to the hob, frame and surrounding cabinets.
- Preferably cover pans with a lid to permit cooking at a lower heat.
- Always cook vegetables and potatoes, etc. in as little water to reduce cooking times.
- Food or liquid that has high sugar content may damage the hob top if it comes into contact with the ceramic hob surface. Any spillages should be wiped up immediately, however this may not prevent the hob surface from becoming damaged.
- ***IMPORTANT: The ceramic hob surface is tough; however it is not unbreakable and can be damaged. Especially if pointed or hard objects are allowed to fall on it with some force.***
- ***DO NOT USE THE HOB IF THE SURFACE BECOMES BROKEN OR CRACKED. YOU SHOULD CONTACT THE CUSTOMER CARE DEPARTMENT IMMEDIATELY.***

## Cleaning and maintenance



***Cleaning operations must only be carried out when the hob is cool.***

***The appliance should be disconnected from your mains supply before commencing any cleaning process.***

### Cleaning the ceramic hob top



Any residues that are left on the hob top surface from cleaning agents **will** damage it. You should remove any residues with warm water mixed with a little washing up liquid.



Abrasive cleaners or sharp objects will damage the hob surface; you should clean it using warm water mixed with a little washing up liquid.



You may find it easier to clean some deposits whilst the hob surface is still warm. However you should take care not to burn yourself if cleaning the hob surface when it is still warm.

### After each use

- Wipe the appliance over with a damp cloth.
- Dry the appliance by rubbing the surface with a clean cloth.

### Cleaning table

<b><i>Type of deposit</i></b>	<b><i>Remove immediately?</i></b>	<b><i>Remove when the appliance has cooled down?</i></b>	<b><i>What should I use to remove the deposit?</i></b>
Sugar or food/liquid containing sugar	Yes	No	Ceramic hob scraper
Tin foil or plastic	Yes	No	Ceramic hob scraper
Fat splashes	No	Yes	Ceramic hob cleaner
Metallic discolouration	No	Yes	Ceramic hob cleaner
Water splashes or water rings	No	Yes	Ceramic hob cleaner

## Using a ceramic hob scraper

Your appliance will be provided with a hob scraper. The following guidelines should also be followed when using the ceramic hob scraper: -

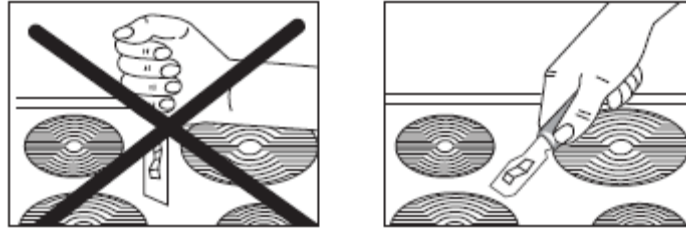

- The scraper should be placed on the ceramic surface at an angle.
- Residues should be removed by sliding the blade carefully over the ceramic surface.
- The ceramic surface should be wiped with a damp cloth that has been placed in warm water mixed with a small amount of washing up liquid.
- Dry the appliance by rubbing the surface with a clean cloth.

## Using a specialist ceramic hob cleaner

It is possible to purchase a specialist ceramic hob cleaner/conditioner.

You should follow the instructions given by the manufacturer of the specialist ceramic hob cleaner. You should ensure that it is suitable for use on your appliance.

## Installation



*The installation must be carried out by a suitably qualified person, in accordance with the current version of the following.*

- ***UK Regulations and Safety Standards or their European Norm Replacements.***
- ***Building Regulations*** (issued by the Department of the Environment).
- ***Building Standards*** (issued by the Scottish Development Department).
- ***IEE Wiring Regulations.***
- ***Electricity At Work Regulations.***

## Positioning



***The adjacent furniture must be able to withstand a minimum temperature rise of 85°C above the ambient temperature of the room it is located in, during periods of use. Materials and glues used for the kitchen cabinets must be able to withstand a temperature of at least 100°C.***

This appliance is classified as Class 3 and therefore is to be built into a kitchen unit (depending on size) or 600 mm worktop that is at least 30 mm thick. The following minimum clearance distances must be observed: -

- 700 mm between the hob surface and the underside of any horizontal surface above it.
- 50 mm clearance around the front, back and sides of the appliance, measured from the cut out.
- If the hob is positioned so that the right or left hand side of the appliance will be near to the edge of a kitchen unit. There must be a gap of at least 150 mm between the side of the hob and the vertical surface of the kitchen unit.

## Unpacking the appliance

When unpacking the appliance please check that the following items are contained within the packaging: -

- 1 Baumatic hob
- 1 Ceramic hob scraper
- 1 Installation and instruction manual
- 1 Baumatic guarantee card
- 4 Fixing brackets
- 4 Fixing screws
- 1 Sealing strip

## Installing the appliance

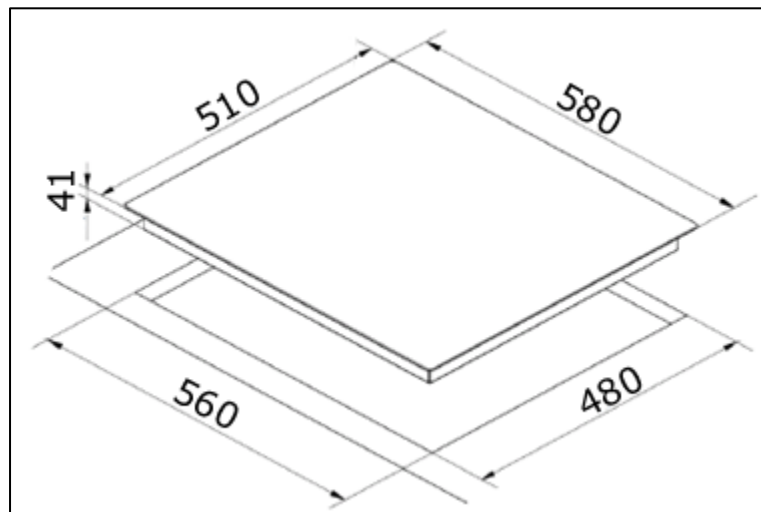

- Cut a hole in the worktop that corresponds with the drawing shown above.
- If the hob is being installed **without** an oven below it, a separator panel must be placed between the bottom of the hob and the housing below it, at a minimum distance of 10 mm.
- If the hob is being installed **with** an oven below it, place a separator panel at a minimum distance of 15 mm and follow the oven manufacturer's instructions, ensuring that sufficient aeration is provided.
- The heat produced by the oven, measured on the right side of the bottom of the hob, must be lower than 60°C, otherwise the heat could damage the touch control panel.
- **IMPORTANT:** You must observe the ventilation requirements shown in the drawing below.

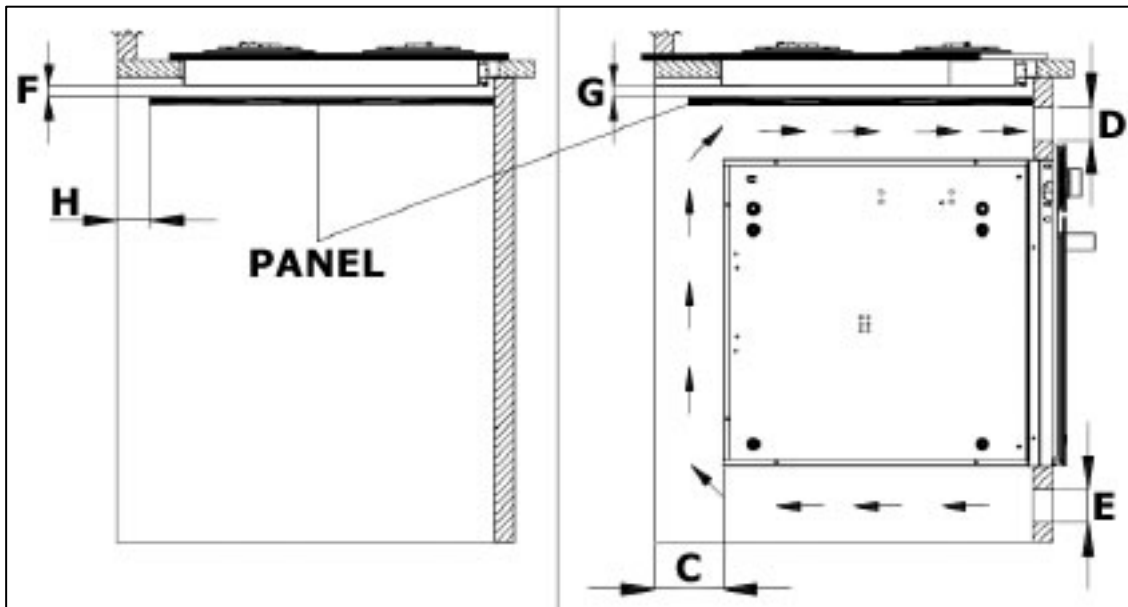

- F = 10 mm (min)
- H = 50 mm (min)
- G = 15 mm (min)
- C = 30 mm (min)
- D = 120 cm<sup>2</sup>
- E = 180 cm<sup>2</sup>

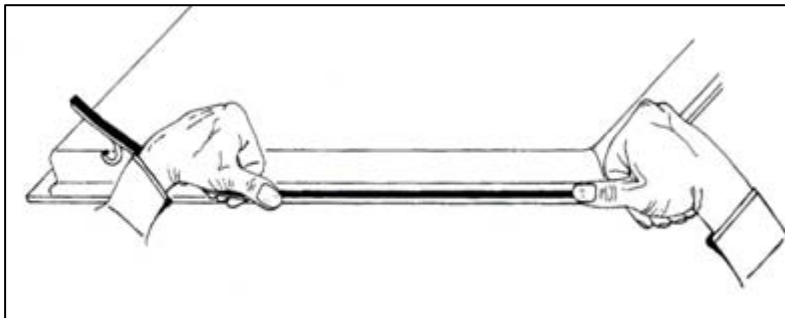

- Carefully turn the hob upside down and place it on a cushioned mat.
- Apply the sealing strip **(A)** provided around the edge of the appliance.
- The protective covering must be removed from both sides.
- Do not leave a gap in the sealing agent or overlap the thickness.
- **IMPORTANT:** Do not use a silicon sealant to seal the appliance against the aperture. This will make it difficult to remove the hob from the aperture in future if it needs to be serviced.



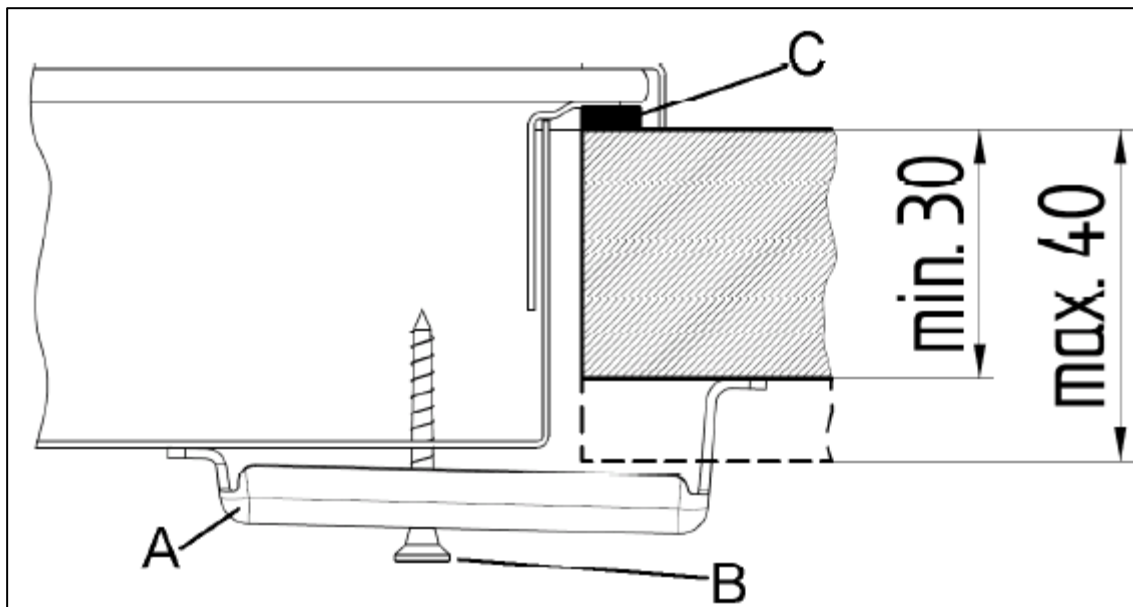

- (A) Clamp
- (B) Screw
- (C) Sealing strip

- Place the clamp **(A)** over the holes that match the size of the screws. There are one set of screw holes in each corner of the hob. Slightly tighten a screw **(B)** through the clamp **(A)** so that the clamp is attached to the hob, but so that you can still adjust the position of it.
- Carefully turn the hob back over and then gently lower it into the aperture hole that you have cut out.
- On the underneath of the hob, adjust the clamps into a position that is suitable for your worktop. Then fully tighten the screws **(B)** to secure the hob into position.

### Electrical connection



***This appliance must be installed by a qualified person in accordance with the latest edition of the I.E.E. Regulations and in compliance with Baumatic's instructions.***

Before connecting the appliance, make sure that the supply voltage marked on the rating plate corresponds with your mains supply voltage.

***WARNING: THIS APPLIANCE MUST BE EARTHED.***

- This appliance must be wired into a 35 A double pole switched fused spur outlet, having 3 mm contact separation and placed in an easily accessible position adjacent to the appliance. It should not be located above the appliance and no more than 1.25m away from it.
- The spur outlet must still be accessible even when your hob is located in its operating position.
- Cable type: H05 RRF 3 core x 6 mm<sup>2</sup>

### Connecting the mains supply cable

- The mains terminal block is located on the underside of the hob and the terminals are accessible by removing the terminal block cover by removing the cover screw.

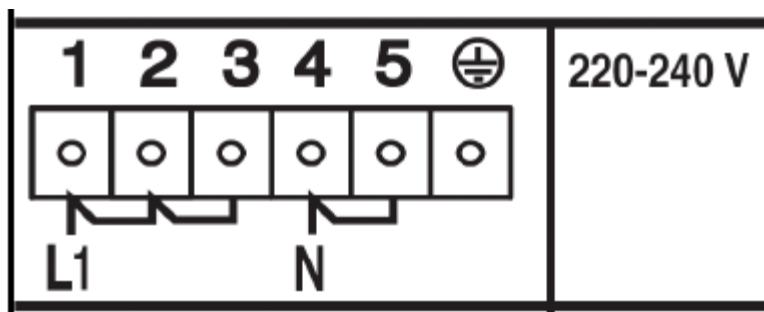

- The brass links must be positioned as marked in the appropriate diagram and once established ALL terminal screws must be tightened down firmly.
- ***If when the hob is first switched on, only two of the zones work, you should recheck that the terminal screws are all fully tightened between the links. This should be done before contacting the Baumatic Customer Care Department.***
- ***IMPORTANT:*** The appliance must NOT be connected to the mains supply by means of a 13A plug and socket.
- The cable can be looped if necessary, but make sure that is not kinked or trapped when the hob is in position. Care must be taken to avoid the cable being in contact with hot parts of the appliance.

## Replacing the mains supply cable

If the mains supply cable is damaged, then it must be replaced by an appropriate replacement.

The mains supply cable should be replaced in accordance with the instructions on the next page:

- ***Switch the appliance off at the socket.***
- Open the terminal block on the underside of the hob.
- Unscrew the terminal screws fixing the cable.
- Replace the cable with one of the same length and in accordance with the specification given on page 26.
- The “green-yellow” earth wire must be connected to the terminal marked  $\perp$ . It must be about 10 mm longer than the live and neutral wires.
- The “blue” neutral wire must be connected to the terminal marked with letter (N) - the live wire must be connected to the terminal marked with letter (L).

## My appliance isn't working correctly

- ***The cooking zones are not functioning or will not switch on.***
- \* It has been more than 2 minutes since the appliance was switched on. You should switch the appliance back on again, using the ON/OFF button and then switch on a cooking zone.
- \* The safety lock has been switched on (see the “Locking the hob top” section for information on how to turn off the safety lock).
- \* Several cooking zone selection buttons have been pressed at once. You should only try to switch on one cooking zone at once.
- \* The safety cut out has been triggered. Press the ON/OFF button to reset the hob.
- \* Check that the mains electrical supply to the appliance is correct and working. Check the mains fuse.

- ***The residual heat indicator has not come on after I have switched a cooking zone off.***
- \* The cooking zone has only been turned on for a short period of time; therefore it did not go above 60°C.
- \* ***IMPORTANT: If the cooking zone does appear to be hotter than 60°C and the residual heat indicator has not come on, you should call the Customer Care Department.***
- ***A humming sound is heard when a cooking zone is selected.***
- \* This is normal; the sound will disappear when the zone heats up.
- ***The cooking zones have become discoloured.***
- \* This maybe caused by burnt on remnants of food. This will not affect the working of the appliance. However you should make sure that the cleaning instructions are being followed regularly.



***IMPORTANT: If your appliance appears not to be operating correctly, then you should disconnect it from your mains supply and then contact the Customer Care Department on telephone number (0118) 933 6911.***

***DO NOT ATTEMPT TO REPAIR THE APPLIANCE YOURSELF.***

Please note that if an engineer is asked to attend whilst the product is under guarantee and finds that the problem is not the result of an appliance fault, then you may be liable for the cost of the call out charge.

***The appliance must be accessible for the engineer to perform any necessary repair. If your appliance is installed in such a way that an engineer is concerned that damage will be caused to the appliance or your kitchen, then he will not complete a repair.***

***This includes situations where appliances have been tiled in, sealed in with sealant, have wooden obstructions placed in front of the appliance, like plinths. Or any installation other than the one specified by Baumatic Ltd. has been completed.***

Please refer to the conditions of guarantee that appear on the warranty card that you receive with the appliance.

***IMPORTANT: Baumatic Ltd. operates a policy of continuous improvement and reserves the right to adjust and modify its products without prior notification.***



***United Kingdom***

Baumatic Ltd.,  
Baumatic Buildings,  
6 Bennet Road,  
Reading, Berkshire  
RG2 0QX  
United Kingdom

**Sales Telephone**

(0118) 933 6900

**Sales Fax**

(0118) 931 0035

**Customer Care Telephone**

(0118) 933 6911

**Customer Care Fax**

(0118) 986 9124

**Spares Telephone**

(01235) 437244

**Advice Line Telephone**

(0118) 933 6933

**E-mail:**

sales@baumatic.co.uk  
customercare@baumatic.co.uk  
spares@baumatic.co.uk  
technical@baumatic.co.uk

**Website:**

www.baumatic.co.uk

***Republic of Ireland***

**Service Telephone**

1-890 812 724

**Spares Telephone**

091 756 771

***Czech Republic***

Baumatic CR s.r.o.  
Lípová 665  
460 01 Liberec 4  
Czech Republic

+420 483 577 200

www.baumatic.cz

***Slovakia***

Baumatic Slovakia, s.r.o.  
Galvániho 7/D  
Slovakia

+421 255 640 618

***Germany***

Baumatic GmbH  
Lilienthalstrasse 1  
320 52 Herford  
Deutschland

+49 5221 694 99-0

www.baumatic.de

***Italy***

Baumatic Italia S.R.L.  
Via Galvani N.3  
35011 Campodarsego (PD)

+3904 9920 2297

www.baumatic.it

***Holland***

Baumatic Benelux B.V.  
Grindzuigerstraat 22  
1333 MS ALMERE  
Nederland

+3136 549 1555

www.baumatic.nl



