

FRANKE FILTERFLOW ZURICH TAP

Installation Instructions

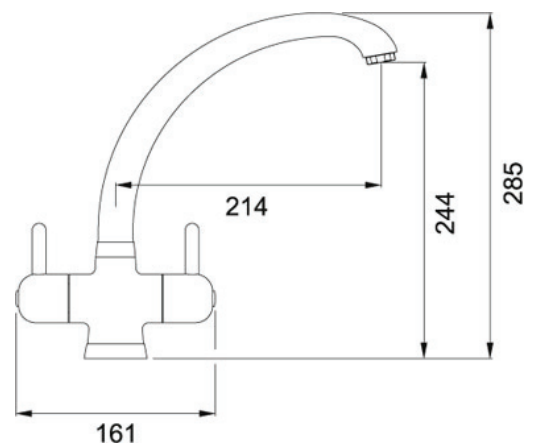

KITCHEN
SYSTEMS

FRANKE

Design

These mixers are available in Chrome and SilkSteel to complement all Franke sinks.

Service

In the event of parts or service being required, please contact:

Franke FilterFlow 0808 165 0008

Preparation

First shut off your water heating system then, with your mains stop cock closed, open the lowest hot and cold taps in the house and allow to run until the cold storage tank and pipes are empty. (The hot water storage cylinder always remains full).

Installation

First screw the threaded stud into the mixer body. Screw the copper tails into the mixer body and fully hand tighten.

After making any necessary alterations to existing pipework, pass the plinth over the tails and fit in position. The shaped upstand on the plinth will locate in the tap body and the 'O'ring should be placed in the recess to make a seal with the sink.

When the tap is in position (with the cold side on the right when viewed from the front) slide the nylon bracing plate up to the underside of the sink together with the retaining plate, and secure by screwing the fixing nut finger tight.

Check that the mixer body and plinth are correctly positioned and fully tighten fixing nut. It is recommended that 15mm x 15mm compression fittings be used to connect mixer to supply pipes. Cold is connected to the right and hot on the left when viewed from the front.

Connecting The FilterFlow

Attention. Before installing the new mixer it is essential that you thoroughly flush through the supply pipes in order to remove any remaining swarf, solder or other impurities.

Failure to carry out this simple procedure could cause problems or damage to the workings of the mixer.

Having first checked all new connections, turn on the mains stop cock, close all taps except the new mixer and as the system starts to refill check for leaks. Once you have satisfied yourself that there are no leaks, switch on the water heating.

Warning: These hints have been prepared for your guidance, you must exercise due care at all times. We do not accept responsibility for any problems that may occur through incorrect installation.

How to care for your kitchen sink mixer

To maintain the appearance of this fitting, ensure it is cleaned only using a clean, soft damp cloth. A solution of warm water and mild liquid detergent may be used where necessary, and then the fitting rinsed thoroughly. Abrasive cleaners or acidic cleaners **MUST NOT BE USED** under any circumstances. Avoid contact with all solvents.

Technical Data

Maximum water pressure:	75 PSI (5 bar)
Maximum hot-water temperature:	70°C
Recommended hot water temperature:	65°C
Minimum water pressure:	22 PSI (1.5 bar)

Note: If these temperatures or water pressures are exceeded damage to the tap can result.

A pressure reducing valve may be required to be fitted in high water pressure situations.

Connecting the Filter System

Locate the 3/8" diameter stem at the base of your Franke FilterFlow filter tap. Wet the stem with a little water. Select the remaining blue plastic tube (B) with the grey plastic push fit connector (A) attached to the free end. Engage the push fit connector on the tail and push it firmly on the stem.

Important. Initial resistance will be felt as the internal 'O' seal is engaged – continue to push the connector past the seal to the final stop. The connector should push on the stem 10mm (3/8"). Failure to fully engage the connector may result in subsequent failure of the joint.

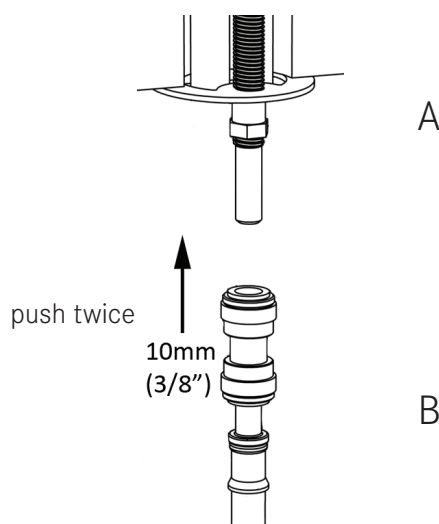

PARTS LIST AS FOLLOWS:

133.0150.225	ZURICH SPOUT CHROME	1258R CH	133.0150.232	ZURICH HANDLE SILK STEEL HOT	3166R-H SS
133.0150.226	ZURICH SPOUT SILK STEEL	1258R SS	133.0201.903	DIVERTER CARTRIDGE	3448R
133.0068.760	ANTISPLASH BLACK	1256R	133.0069.960	HOT VALVE	1212R H
133.0150.227	SPOUT FIXING COLLAR CHROME	1244R CH	133.0194.035	FILTER FLOW FIXING KIT	3622R
133.0150.228	SPOUT FIXING COLLAR SILK STEEL	1244R SS	133.0069.184	SET OF COPPER TAILS	1234R
133.0069.151	O.RING KIT	1239R	133.0201.905	FILTER FLOW ZURICH BASE PLINTH CHROME	3578R CH
133.0150.229	ZURICH HANDLE CHROME COLD	3166R-C CH	133.0201.906	FILTER FLOW ZURICH BASE PLINTH SILK STEEL	3578R SS
133.0150.230	ZURICH HANDLE CHROME HOT	3166R-H CH	133.0194.133	TRIANGULAR PLASTIC PLATE	3618R
133.0150.231	ZURICH HANDLE SILK STEEL COLD	3166R-C SS			

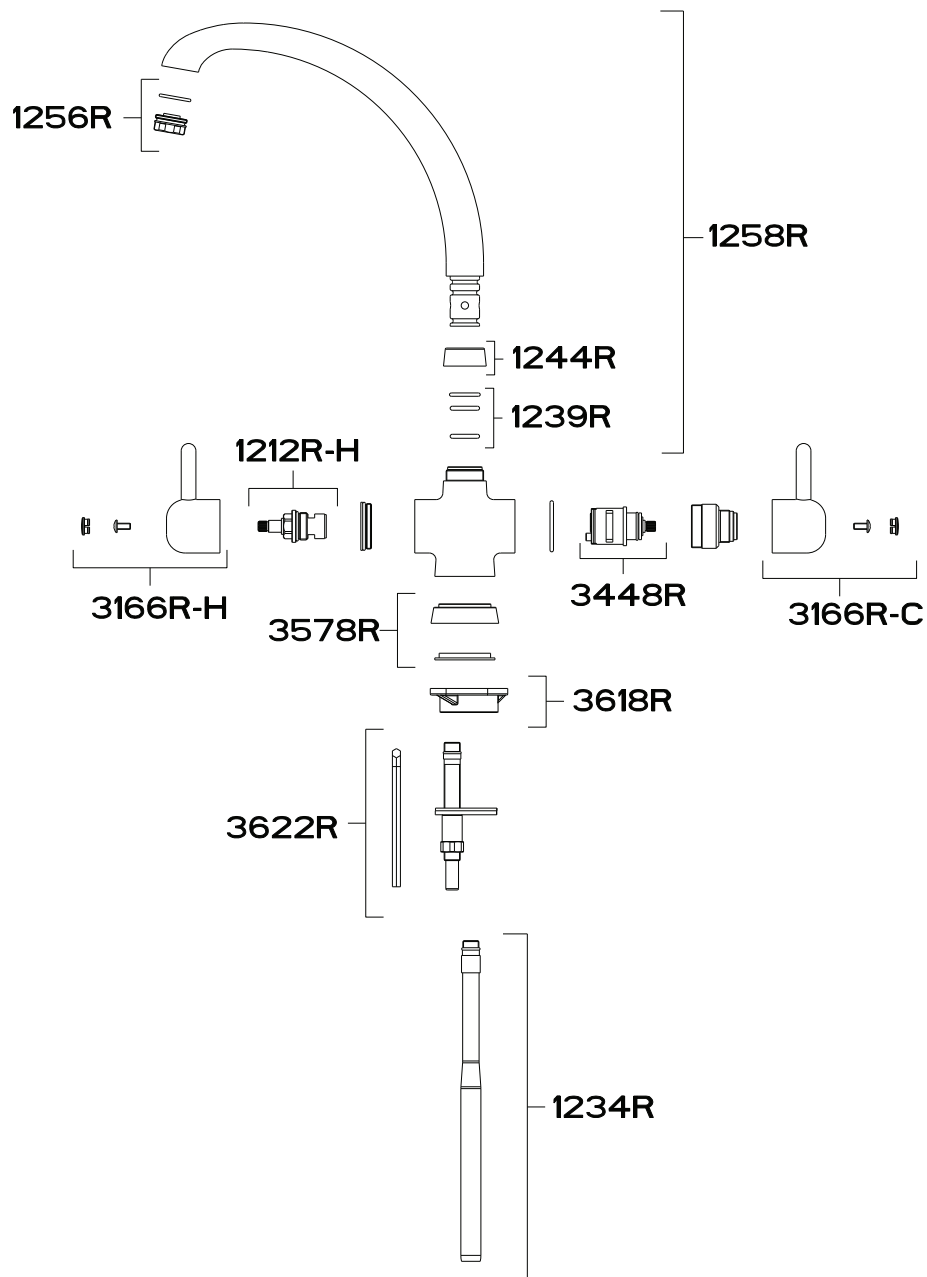

Guarantee

Your Franke FilterFlow tap has been manufactured to the high standard you would expect of any Franke product but in the unlikely event that you should experience any defect in the materials or workmanship within one year of purchase*, we will replace the faulty part free of charge. This is provided the mixer has only been used for normal domestic purposes in the UK and that the care, installation and maintenance instructions have been observed.

You should also retain your dated invoice as proof of purchase to validate any claims under our guarantee.

This one year guarantee is extended to five years in the case of the valve mechanisms.

*Normal wear and tear is excluded from the guarantee.

Decorative surface finishes are guaranteed for one year from the date of purchase provided our advice concerning care has been observed and no scouring agents have been used.

Scuffs and scratches caused by improper installation or accidental damage are not covered by this guarantee. Neither are slight shade variations or any damage or defect caused by incorrect installation or abuse of the fitting.

Franke UK Limited
West Park, MIOC
Styal Road
Manchester
M22 5WB
Phone +44 (0)161 436 6280
Fax +44 (0)161 436 2180
Email info.uk@franke.com
www.franke.co.uk

After Sales Service

Franke FilterFlow
3 Old Winery Business Park
Chapel Street
Cawston, Norfolk
NR10 4FE
Phone +44 (0)808 165 0008
Fax +44 (0)844 358 0166
Email info@frankefilterflow.com
www.frankefilterflow.co.uk



KITCHEN
SYSTEMS