

PRODUCT INSTRUCTIONS

Product Code : **2600K** Description : **15mm 22mm Pipe Bender**

INSTRUCTIONS

Please follow these instructions in conjunction with Figs A, B and C.

- Ensure all formers and guides are clean and free from flux residues or other dirt.
- Position the bending lever (1) at right angles to the centre line of the pipe bender.
- Position the pipe to be bent, into the groove of the appropriate (15mm (2) or 22mm (3)) former.
- Ensure the pipe is positioned under the appropriate part of the hook stop (4).
- Slide either end of the appropriate (15mm or 22mm) guide (5) under the steel roller (6).
- Move the bending lever (1) until the steel roller (6) is just touching the guide (5).
- Ensure the pipe is positioned correctly so the pipe will be bent at the required point.
- Apply enough pressure to the end of the bending lever (1) to produce the required angle of the bend.
- The bend can either be produced by hand bending, Fig B., or by using the floor as a support for the fixed arm, Fig C.
- Alternatively the base of the bracket (7) can be held in an engineer's vice to support the pipe bender.

MAINTENANCE

To ensure long life, keep the bender clean and free from flux residues and other dirt. Oil moving parts regularly.

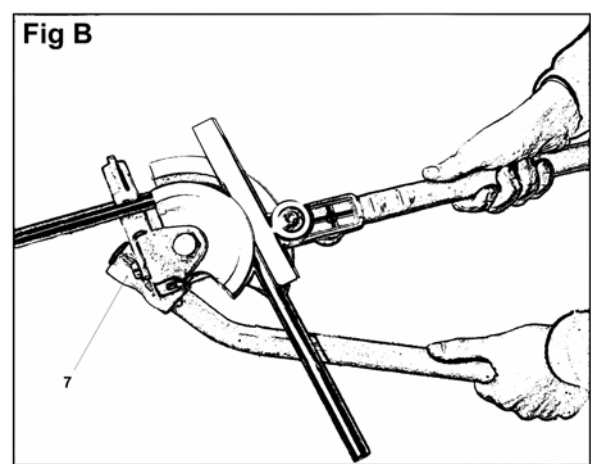
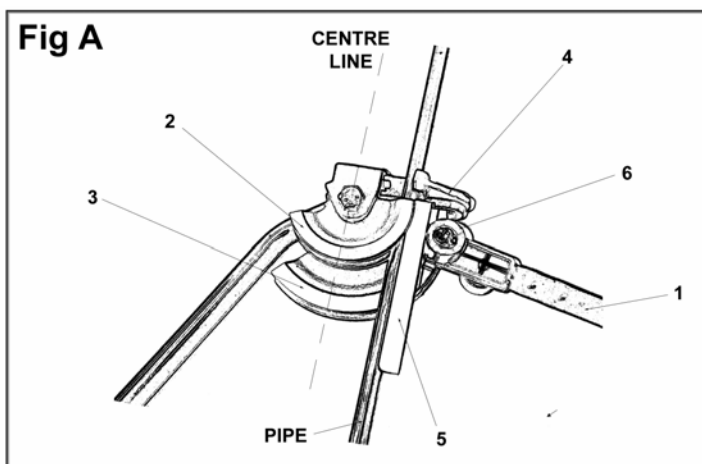

Monument Tools Ltd.
Restmor Way • off Hackbridge Road
Hackbridge • Wallington • Surrey
SM6 7AH • United Kingdom

Tel : +44 (0)20 8288 1100
Fax : +44 (0)20 8288 1108
Email : info@monument-tools.com

MONUMENT

www.monument-tools.com

Over 70 years of excellence as hand tool manufacturers and distributors of equipment for the plumbing and drainage industry
Registered in England at the above address, certificate no. 281817. VAT Registered No. GB 217 8102 81

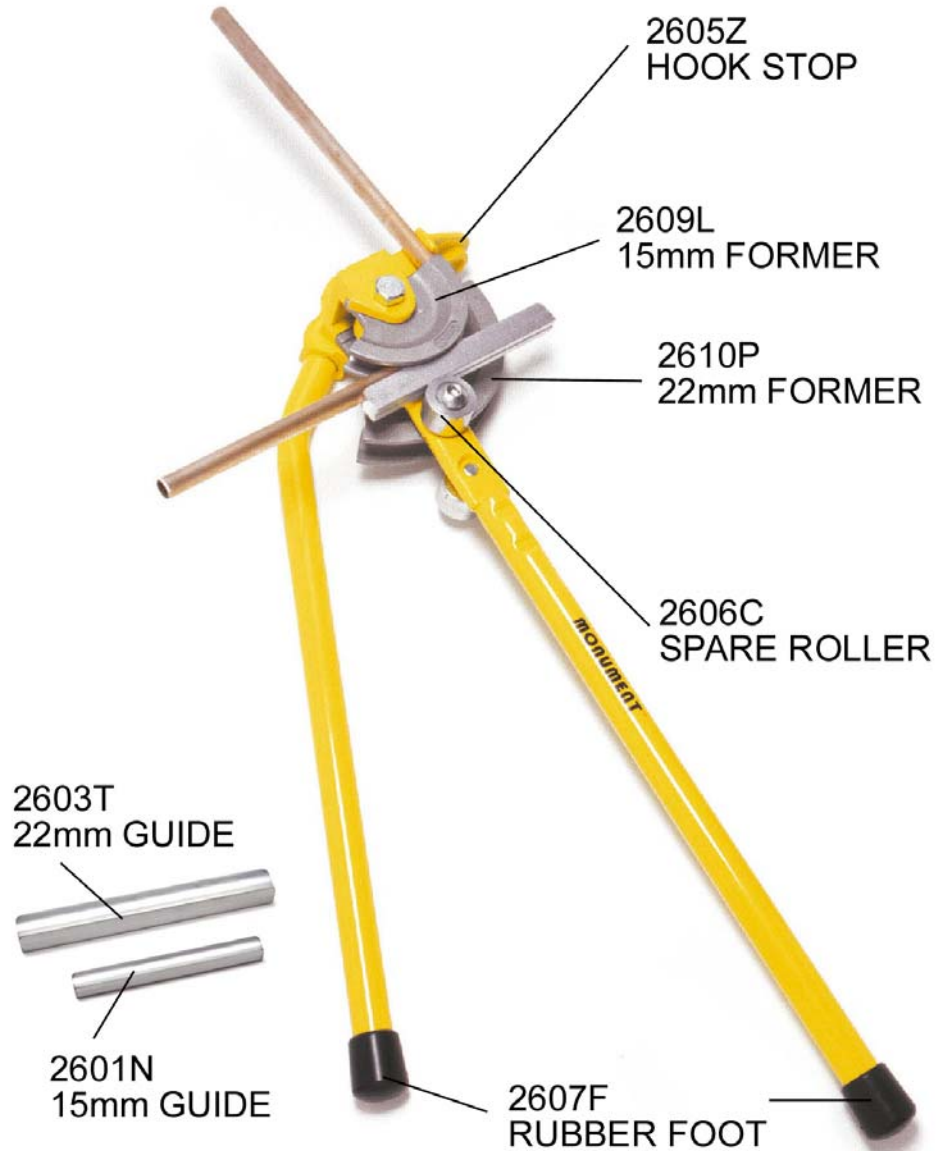
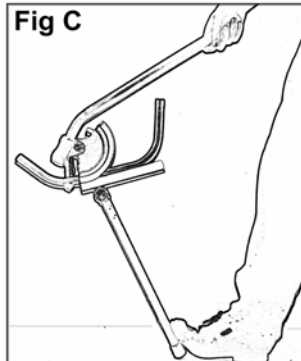

Member
COMITÉ EUROPÉEN DE L'OUTILLAGE
EUROPEAN TOOL COMMITTEE • EUROPAISCHES WERKZEUGKOMITEE

